



# UHF Tire Patch Tag

85 x 38 x 2.5 mm H9



UHF Tire Patch RFID Tire Tag technology provides a permanent digital identity for every tire in your inventory. We build these tags with specialized rubber materials to withstand the extreme heat and pressure of daily road use. Because they operate on the global 860-960MHz frequency, they allow for rapid data collection throughout the production, storage, and sales phases. This solution helps tire factories and transportation companies automate traceability with total accuracy.

It will last the lifetime of the tire. It should be attached outside the sidewall of the tire with vulcanizing agent, mainly used for bus tire, truck tire, trailer tire, etc.

## Highlights & Benefits

- ✓ Outstanding performance
- ✓ Flexible material to contour to any shape of tire
- ✓ ETSI(865-868 MHz) and FCC(902-928 MHz) optional
- ✓ Customization-design, printing, encoding available

## Applications

- ✓ Vehicle and truck management
- ✓ Tire anti cloning and brand protection
- ✓ Tire inventory tracking and anti theft



## Technical Features

Model	RC9020-2
<b>RFID Features</b>	
Air Interface Protocol	EPC Class 1 Gen 2 / ISO 18000-63 Type C
Frequency	860-960 MHz
Chip Type	Alien Higgs 9
Memory	User - 688 bits; EPC - 96 bits(up to 496 bits)
Data Storage	> 10 years
Re-write	100,000 times
Read Range(2W ERP)	FCC: > 3.8 m(12.5 ft) , on rubber ETSI: > 2.5 m(8.2 ft) , on rubber
<b>Physical Features</b>	
Dimension	85 x 38 x 2.5 mm / 3.35 x 1.50 x 0.10 in
Material	Rubber
Weight	5.0 g
Color	Black
Operating Temperature	-40°C to 85°C / -40°F to 185°F
Survival Temperature	-40°C to 230°C / -40°F to 446°F
Storage Condition	20±5°C, 50±10% RH, Store away from sunlight
IP Rate	IP68, test for 5 hours at 1m deep water
<b>Other Features</b>	
Installation	Fixed to the inner side wall using double curing glue or heating
Customization	Printing, Encoding, Design, etc.
Package	120 pcs / bag, 10 bags / box

### Radiation Pattern

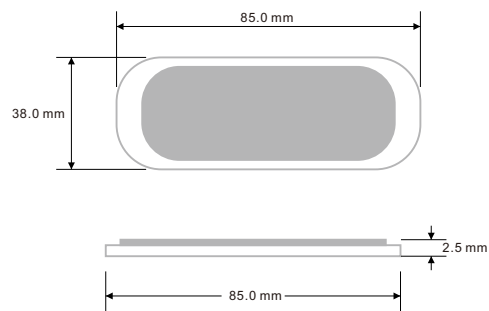
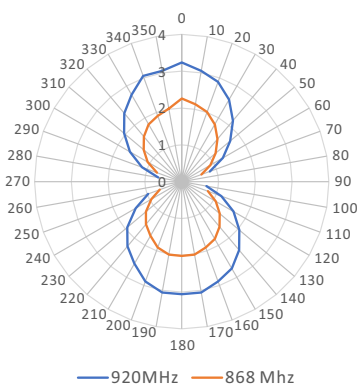

PS: The performance is theoretical values in the lab and the actual effect depends on the specific applications.

**RICHRFID**

Web: <https://www.richrfid.com> E-mail: [info@richrfid.com](mailto:info@richrfid.com)  
Shenzhen | Hong Kong | Singapore | Seoul | Tokyo | Paris



#### DISCLAIMER

All specifications are indicative and results may vary. Each user bears full responsibility for making its own determination as to the suitability of RICHRFID products, materials, services, recommendations, or advice for its own particular use.

For intended use only. Not to be repurposed or used for other applications without prior written permission from the manufacturer.

@2026 RICHRFID. All rights reserved.