



Flmeta Slim

20 x 10 mm U8

Due to the fact that both metal and liquid are highly conductive materials that reflect or absorb UHF radio waves, they can detune nearby antennas or even completely block the signal. As a result, standard RFID labels generally perform poorly on metal surfaces or liquid-filled containers.

By means of specialised antenna design and materials, RICHRFID Flmeta anti-metal&liquid labels could operate splendidly and reliably on metal surface and liquid-filled containers, also perform competently on non-metal and non-liquid items, though not at peak performance.

Fully compliant with the EPC C1G 2 (ISO 18000-6C) protocol and the frequency 860–960 MHz, our Flmeta offer a data retention period exceeding 10 years and support up to 100,000 write cycles. Constructed from PET, aluminum foil, and foam, they deliver exceptional tear resistance and structural durability, providing effective protection against physical damage and rupture.

Their slim profile and availability in roll form ensure seamless compatibility with RFID printers, enabling simultaneous printing and encoding.

The self-adhesive backing and inherent flexibility further enhance their versatility, allowing for reliable application on both flat and curved surfaces. Typical use cases include asset tracking for IT equipment, electronic devices, cosmetics, beverages (both alcoholic and soft drinks), industrial components, pharmaceuticals, and ESD containers, among others.

Highlights & Benefits

- ✓ **Superior performance on diverse surfaces:** Optimized for metal, liquid-filled containers, plastic, and more.
- ✓ **Ready for RFID printing:** Fully printable and programmable with standard RFID encoders/printers.
- ✓ **Flexible and conformable:** Self-adhesive, thin, and flexible design ensures reliable adhesion on curved surfaces.
- ✓ **Durable construction:** Features a waterproof PET face material for enhanced longevity.
- ✓ **Global frequency options:** Available in ETSI (865–868 MHz) and FCC (902–928 MHz) standards.
- ✓ **Fully customizable:** Supports bespoke design, on-demand printing, and encoding services.

Applications

- ✓ Facility & equipment
- ✓ Fixed asset
- ✓ Electronics
- ✓ Liquid container
- ✓ Metal parts

Technical Features

Model	RCO7070
RFID Features	
Air Interface Protocol	EPC Class 1 Gen 2 / ISO 18000-63 Type C
Frequency	860-960 MHz
Chip Type	NXP Ucode 8
Memory	User - N/A; EPC - 128 bits; TID - 96 bits
Data Storage	> 10 years
Re-write	100,000 times
Read Range(2W ERP)	FCC: > 1.5 m(4.9 ft), on metal
Physical Features	
Dimension	20 x 10 x 1 mm / 0.79 x 0.39 x 0.04 in
Face Material	White PET
Operating Temperature	-40°C to 85°C / -40°F to 185°F
Survival Temperature	-40°C to 120°C / -40°F to 248°F
Storage Condition	20±5°C, 50±10% RH, Store away from sunlight
IP Rate	IP68, test for 5 hours at 1m deep water
Other Features	
Installation	Adhesive on clean & dry surface
Customization	Printing, Encoding, Designing, etc.
Support Printer	SATO CL4NX, Zebra ZT410 RFID Silverline and ZT411 On Metal, TSC Printronix T6000e, etc.
Recommended Ribbon	Resin-based
Package	1,000 pcs / roll, 4 rolls / box

Radiation Pattern

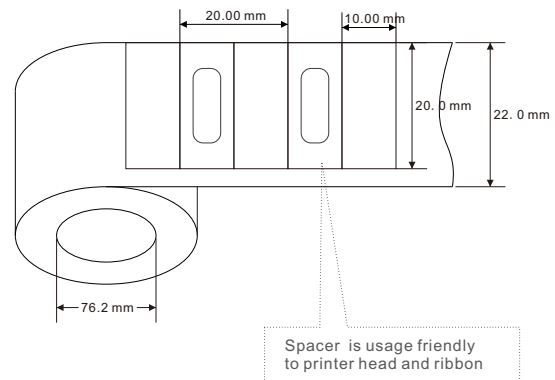
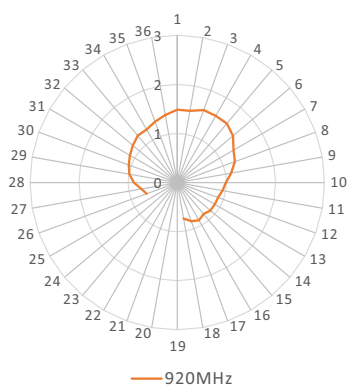

PS: The performance is theoretical values in the lab and the actual effect depends on the specific applications.

RICHRFID

Web: <https://www.richrfid.com> E-mail: info@richrfid.com
 Shenzhen | Hong Kong | Singapore | Seoul | Tokyo | Paris



DISCLAIMER

All specifications are indicative and results may vary. Each user bears full responsibility for making its own determination as to the suitability of RICHRFID products, materials, services, recommendations, or advice for its own particular use.

For intended use only. Not to be repurposed or used for other applications without prior written permission from the manufacturer.

@2026 RICHRFID. All rights reserved.